

# 1000 GALLON TALL DRYWELL

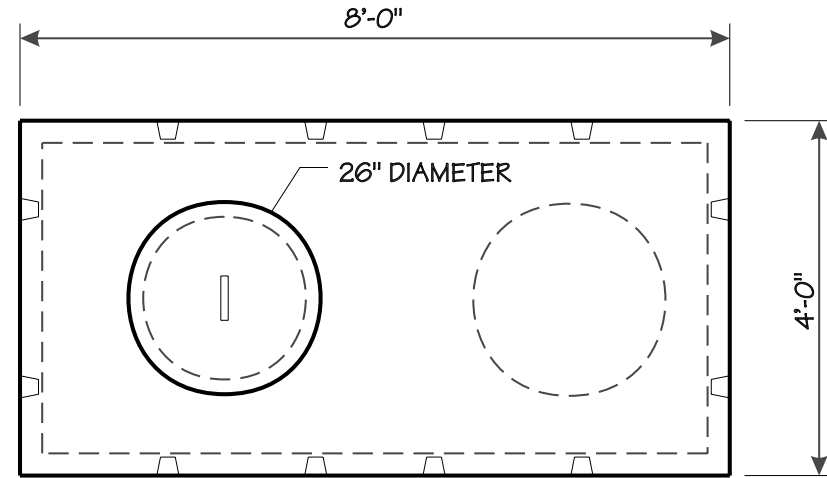
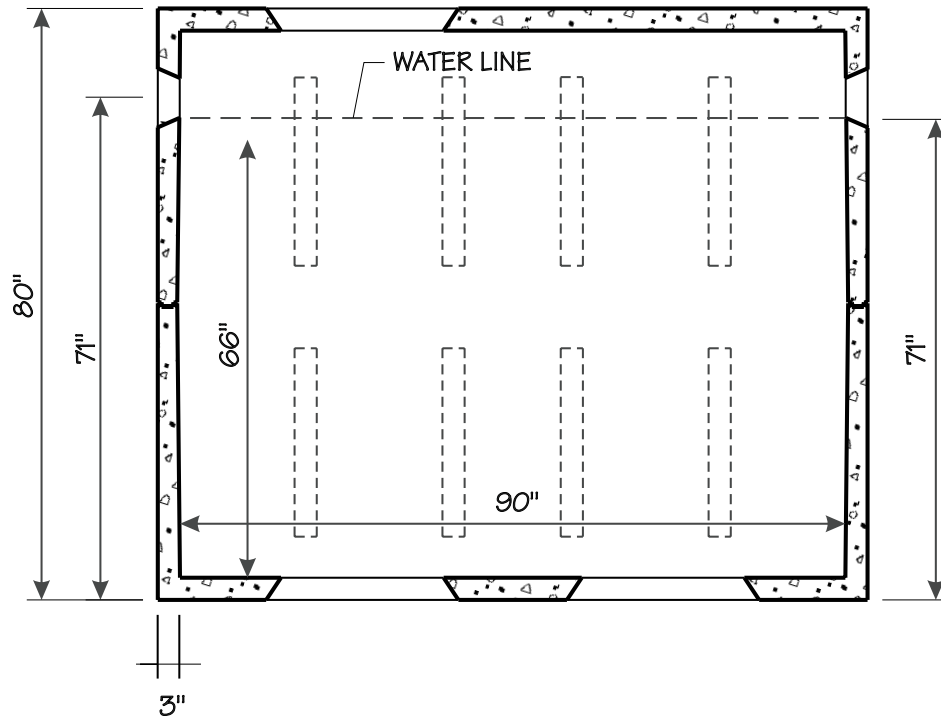

JOINT DETAIL

**VOLUME - CAPACITY:**

**FABRICATION SPECS:**

CAPACITY: 90" x 42" x 66" = 1080 GAL.

REINFORCEMENT - 4" x 4" x 14/14 GALVANIZED WIRE FABRIC

GALLONS PER INCH = 16.4

CONCRETE - 4000 PSI (AIR ENTRAINED)

OVERALL WEIGHT: 6880 LBS.



4944 Mason Road, Howell, MI 48843  
 PH 517 546-2810 FAX 517 546-4480  
[www.americanconprod.com](http://www.americanconprod.com)