

# 500 GALLON DRYWELL

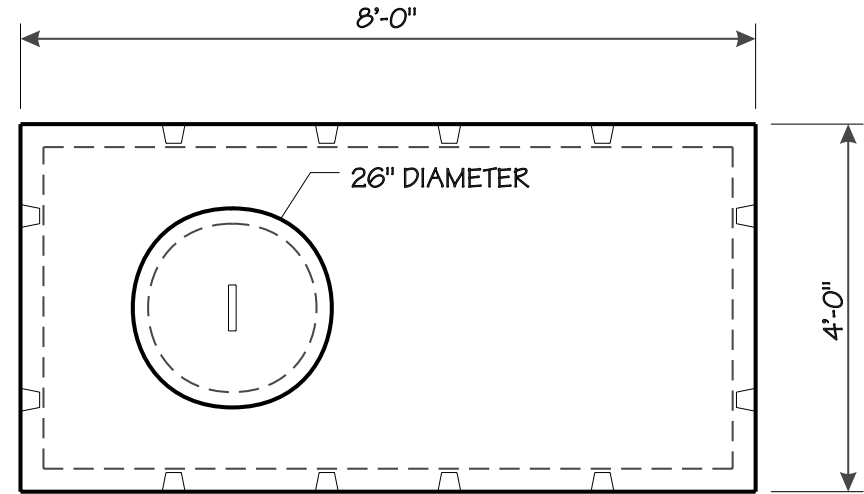
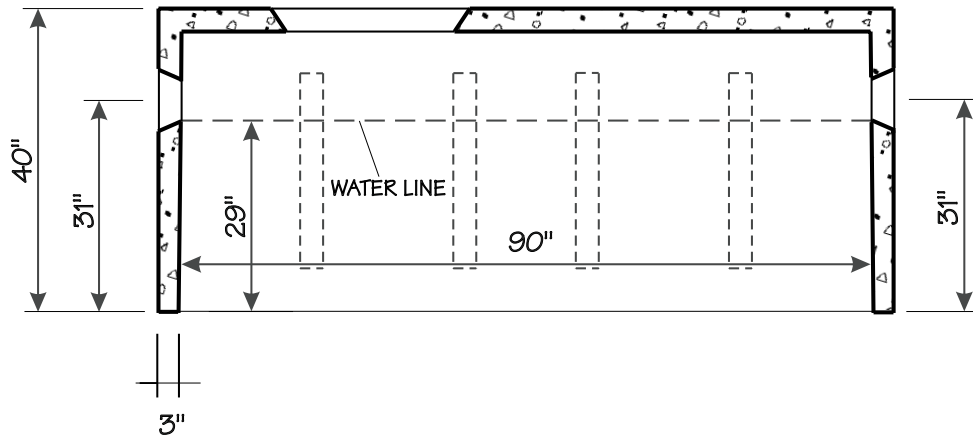

### VOLUME - CAPACITY:

### FABRICATION SPECS:

CAPACITY: 90" x 42" x 29" = 475 GAL.

REINFORCEMENT - 4" x 4" x 14/14 GALVANIZED WIRE FABRIC

GALLONS PER INCH = 16.4

CONCRETE - 4000 PSI (AIR ENTRAINED)

OVERALL WEIGHT: 3440 LBS.



4944 Mason Road, Howell, MI 48843  
 PH 517 546-2810 FAX 517 546-4480  
[www.americanconprod.com](http://www.americanconprod.com)